



RiDom

Opening detector «Ri-DO-1»



Installation guide

1 GENERAL INFORMATION

1.1 The «Ri-DO-1» opening detector (hereinafter referred to as the Detector) sends alarm notifications via a two-way radio channel in accordance with the «Ri-Contact-R» protocol in case if windows, doors and other structural elements where the Detector is installed are being opened or moved and to shifted.

1.2 The Detector works as part of the RiDom smart home protection system, communicating with the «Ri-HUB-1» control center (hereinafter referred to as the Hub), which supports the «Ri-Contact-R» radio channel exchange protocol.

1.3 Control of opening or displacement is carried out by the monitoring of the status of the built-in reed switch.

1.4 The Detector does not require permission and registration as the radio frequency device.

1.5 Two frequencies are used for the exchange of radio signals between the Detector and the Hub - the main and the backup. The transition to the backup frequency happens automatically.

1.6 The Detector generates and provides radio transmission of seven types of notifications:

- the normal status;
- the alarm;
- the opening the case or removal from the place of installation;
- the battery discharge;
- the working in the «Linking» mode;
- the working in the «Identification» mode;
- the quality of communication.

1.7 The radio exchange is initiated by the Detector with a period of 10 s, 15 s, 30 s, 60 s, 2 min, 5 min, 10 min. The frequency of radio sessions is set when configuring the Detector. Alarms and case opening notifications are transmitted immediately.

1.8 The Detector is designed for continuous round-the-clock operation.

1.9 The Detector is resistant to electromagnetic interference.

2 SPECIFICATIONS

Table 1

Parameter	Value
Frequency range	868,7...869,2 MHz
Radiation power, no more	25 mW
Distance between sensor and magnet: - to open the contacts of the reed switch - to close the contacts of the reed switch	More than 20 mm Less than 5 mm
Standby mean time to failure	60 000 hrs
Protection class	IP30
Battery type	CR123A, 1 pc.
The duration of the sensor operation from one battery under normal climate conditions and with communication period of at least 30 s	5 years
Dimensions	97x25x22 mm
Weight	50 g
Average service life	8 years
Operational conditions	
Operating temperature range	-20... +55 °C
Permissible air humidity at a temperature of +25 °C, without moisture condensation	Up to 98 %

3 SCOPE OF SUPPLY

Table 2

Name	Qty.
Opening detector «Ri-DO-1»	1 pc.
Magnetic element	1 pc.
Pad 5 mm	1 pc.
Pad 9 mm	1 pc.
Screw 3-3x30.016	4 pc.
Lithium battery CR123A	1 pc.*
Installation guide for the «Ri-DO-1»	1 copy.

* Included

4 VIEW AND DESIGN

The Detector consists of a case cover and a case base with a printed circuit board (1) mounted inside. There are fixing holes for the convenient mounting in the bottom (8) and on the side (9). The printed circuit board contains: built-in reed switch (2), RESET contacts (3), tamper switch (4), battery holder (5) and antenna (7).

A magnetic element (10) from the delivery set is used to control the built-in reed switch.

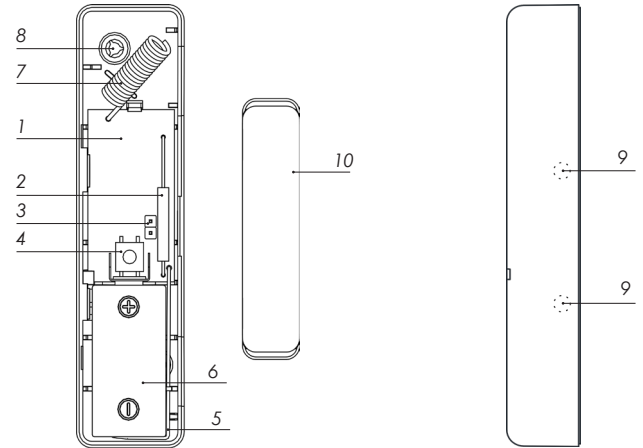

Picture 1 – «Ri-DO-1» view

5 INDICATION

The Detector generates the following types of indication:

- indication of the «Linking» mode (registration of the Detector in the Hub);
- indication «Identification» turns on upon the receipt of the appropriate command from the Hub and remains active for 15 minutes or until the case is opened;
- indication of the sensor status turns on and remains active in the first 15 minutes after the case is closed in the absence of any other types of indication, provided that during this time the «Tamper» notification is not generated or the command is not transmitted from the Hub to disable the indication.

The LED indicating modes are shown in Table 3.

Table 3

LED status	Indication	Notes
«Linking»	intermittent green indicator light	registration of the Detector in the Hub
Completion of «Linking»	turning on the indicator light in red for 2-3 s	
«Identification»	alternating red and green indicator light	the corresponding command was received from the Hub
«Alarm»	single red indicator light with a period of 4 s	Status indication is on and «Identification» indication is off
Connection quality	see the section «Assessing the quality of communication»	
«Normal»	Off	

6 CHOOSING THE PLACE OF INSTALLATION

6.1 The Detector should be installed indoors only.

6.2 The magnet should be placed on the side of the Detector's built-in reed switch.

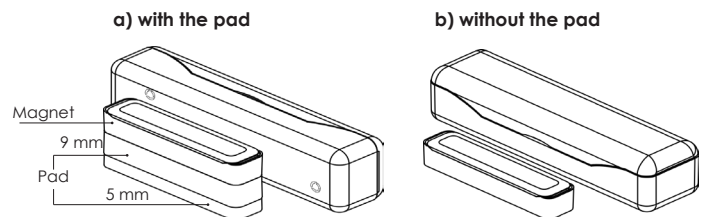

Picture 2 – Installation variants

6.3 It is not recommended to install the Detector on metal surfaces. When installing on metal surfaces, use the pads (included).

6.4 The distance from the Detector or magnet to the magnetically conductive material must be at least 10 mm.

6.5 In any acceptable positions of the controlled structure, the Detector and the magnet should not experience any mechanical impacts (compressions, shocks, etc.).

DO NOT install the Detector if the following cases:

1. In close proximity to electrical wiring.
2. Outdoors.
3. In rooms with temperature and humidity outside the allowable.

7 CONNECTING THE DETECTOR TO THE SYSTEM

7.1 Open the RiDom application and click **+** in the My Devices tab. Then press **Add device** button. Select the «RI-DO-1» sensor from the list of devices and follow the prompts in the application.

7.2 When prompted by the application, remove the battery isolator.

7.3 The Detector will periodically turn on the green LED, that indicates that it is in the «Linking» mode.

7.4 Upon successful connection to the Hub, the indicator on the Detector will turn red for 2-3 seconds, then you can see the Detector in the application, as well as all the data about the sensor. Link mode time is limited to 70 seconds. To resume the «Linking» mode, it is necessary to briefly close the «RESET» contacts.

7.5 Put the case cover back.

8 RADIO CONNECTION QUALITY ASSESSMENT

8.1 Before the installation of the Detector, it is advisable to check the quality of communication with the Hub:

- Place the Detector with the cover closed at the site of installation.
- Press and release the tamper switch.

8.2 When the case tamper switch is released, the Detector generates a case intrusion notification, transmits it via a radio channel and displays the quality of radio communication with the Hub in accordance with Table 4.

Table 4 - Indication of the communication quality control results

Indication		Connection quality	Recommendations
Color	Mode		
Green	Three blinks	Perfect	Installation in this location is allowed
Green	Two blinks	Good	
Green	One blink	Weak	Choose a different installation location or use a repeater
Red	Multiple blinks	No connection	

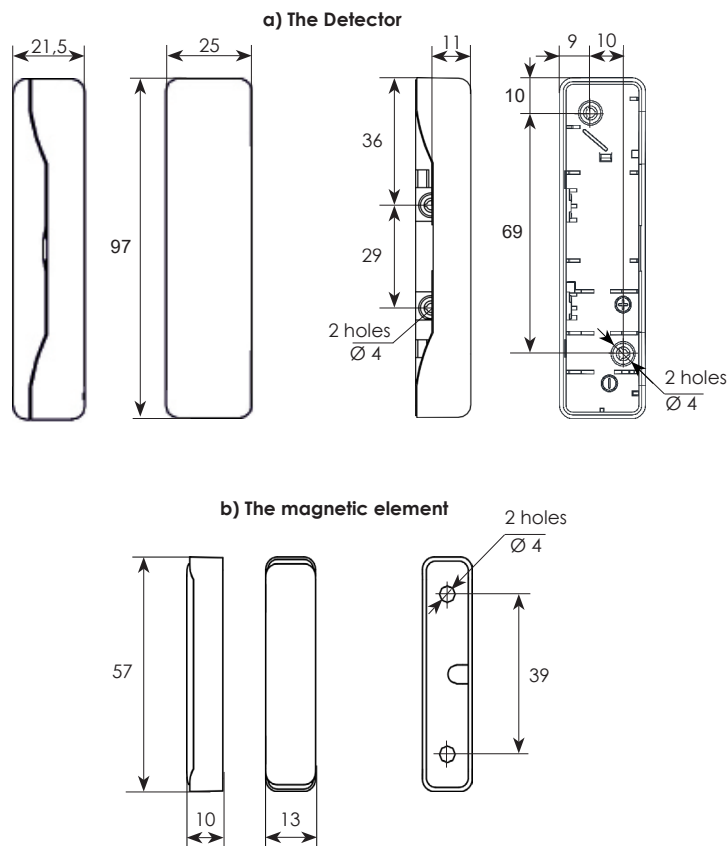
Overall and mounting dimensions (in mm)

Picture 3 – Overall and mounting dimensions

9 STORAGE AND TRANSPORTATION

- 9.1 The Detectors in their original packaging are resistant to:
- transport jolting with the acceleration up to 30 m/sec² at impact frequency range from 10 to 120 per minute or 15 000 strikes;
 - ambient temperature range minus 50 ... +55 °C;
 - relative air humidity (95 ± 3) % at a temperature +35 °C.

9.2 The Detectors in original package may be transported by any means of transportation in closed vehicles over any distances in compliance with the existing shipping rules concerning the respective means of transportation.

9.3 After transportation under the conditions different to exploitation conditions the Detectors shall be ready to operate after a maximum of six hours.

9.4 During storage period lithium batteries should be removed from the holders or isolators should be installed.

Note: The storage premises should not contain any current-conducting dust, acid and alkali fumes, or corrosive or destroying insulation gases.

10 DISPOSAL INFORMATION

10.1 The Detector does not contain precious metals, hazardous or toxic substances that can harm human health or the environment, and does not pose a danger to life, human health and the environment at the end of its service life.

10.2 In this regard, the disposal of the Detector can be carried out according to the rules for the disposal of general industrial waste.

11 MANUFACTURER WARRANTY

11.1 LLC NPP RIELTA guarantees that the Detector meets the requirements of technical specifications within 39 months from the date of manufacture, subject to the conditions of transportation, storage, installation and operation.

11.2 Warranty period of operation of the Detector is 36 months from the date of commissioning within the warranty period of storage.

11.3 If during the warranty period the Detector, which is subject to the rules of transportation, installation and operation, is found to be inconsistent with the requirements of the technical specifications, it is to be replaced or repaired by the manufacturer.

12 DATE OF MANUFACTURE

_____ month, year



ridom.ru

Made in Russia

v10.2R