



COMBINED PIR + GLASS BREAK DETECTOR

«ORLAN-SH»



Installation Guide

General Information

Combined PIR + glass break detector «Orlan-Sh» (hereinafter, the Detector) is designed for application as a component of security systems.

- The Detector has the following two independent detection channels:
 - Glass break channel (hereinafter, GB channel);
 - Passive infrared channel (hereinafter, PIR channel).

GB channel is intended for detecting destruction of engineering structures made of plate glasses as well as glass bricks.

PIR channel is assigned for detecting intrusion into protected area of closed premises.

The Detector provides protection against case tampering by microswitch contacts opening.

The Detector is resistant to the impacts of ambient light, radio noise, as well as disturbance from small animals: mice, rats, birds in cages if a distance to them is not less than 2.5 m.

The Detector can be installed on the wall or in the corner of the room. Wall or ceiling mounting by means of swivel bracket (supplied) is also possible.

Features

- Sensing element of detection channels:
 - PIR channel – dual-element pyrodetector;
 - GB channel – microphone.
- Microprocessor-based signal processing.
- Self-test mode.
- Alarm at PIR and GB channels memorization (alarm memory).
- Possibility of PIR and GB channels sensitivity modes choosing.
- Possibility of LED indication disabling.
- Protection against ingress of insects to the pyrodetector.
- Possibility of swivel bracket using for the detection zone position alignment.

Specifications

Table 1

Parameter	Value
Maximum PIR channel detection range	not less than 10 m
Maximum detection range GB channel	6 m
Output PIR and GB relay contacts	voltage up to 72 V, current up to 30 mA
GB channel sensitivity (HF)	minimum /+7 dB/+14 dB/+21dB
Alarm message duration, not less than	2 sec
Minimum controlled glass area	0.1 m ²
Warm-up time after energizing, not more than	60 sec
Operating temperature	minus 20 °C ... +45 °C
Relative humidity at +25 °C without moisture condensation	90 %
Dimensions, max	110 x 58 x 45 mm
Weight, not more	0.15 kg

PIR channel detection zone pattern is shown in Figure 1, GB channel detection pattern – in Figure 2.

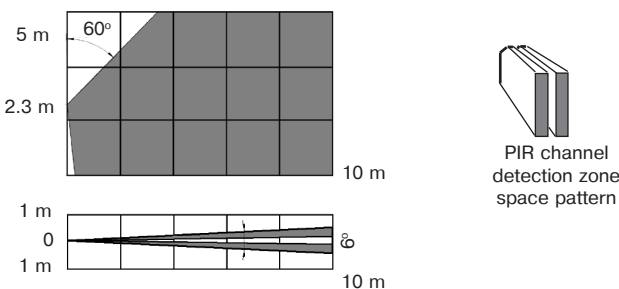

Figure 1 – PIR channel detection zone pattern

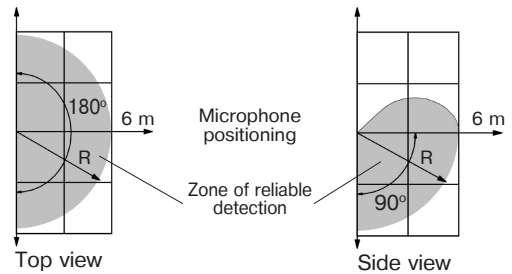

Figure 2 – GB channel detection zone pattern

Scope of Delivery

Each Detector unit package contains items listed in Table 2.

Name	QNT
Combined PIR + glass break detector «Orlan-Sh»	1 pc.
Accessories set:	
Swivel bracket	1 pc.
Screw nut «SORMAT» 5x25	2 pcs.
Screw 3-3x30.016	2 pcs.
Testing ball	1 pc.*
Combined PIR + glass break detector «Orlan-Sh». Installation Guide	1 copy

* Supplied optionally

Choosing Place of Installation

When choosing the Detector installation place, it is advisable to take note of the fact that the detection zone may be screened by non-transparent objects (curtains, houseplants, cabinets, bookcases, etc.), as well as by glass and mesh partitions. There must be no windows, air conditioners, space heaters or heating radiators in the PIR detection zone.

Distance between the Detector and the farthest point of the monitored glass should not exceed 6 m. The Detector microphone should be oriented strictly towards the protected surface of a glass construction.

In case of 1 m² area monitoring maximal distance to the Detector should be increased up to 9 m. Recommended installation height is 2.3 m. In case of swivel bracket usage, installation height is 2.3 – 3.0 m provided that PIR detection zone is aligned.

The Detector wires should be laid at a distance not less than 0.5 m from power supply cables.

Installation of the Detector

- Put off access hole of the Detector (2).
- Remove cover with the printed circuit board (PCB) (4, 3) from the base (1) by pulling towards yourself and downward.
- Open holes in the base for the Detector wiring and fastening the base.
- Choose the place of installation, mark the places for mounting holes with regard to the openings on the detector base, drill holes in the place of installation.
- Pass the wire through the mounting holes in the base, leaving enough length of the wire for hooking up to the Detector terminals.
- Fix the base of the detector (swivel bracket) on the chosen place.
- In case of swivel bracket using, reverse the cap screw (5) from the swivel bracket sphere. Fit the square bulge of the swivel bracket external sphere with the corresponded opening on the detector base. Plug in the screw to the opening in the top of the detector base and fix the connection by the screw without tightening.
- Set the base in desired position and tighten the screw to ensure the base stable fastening.

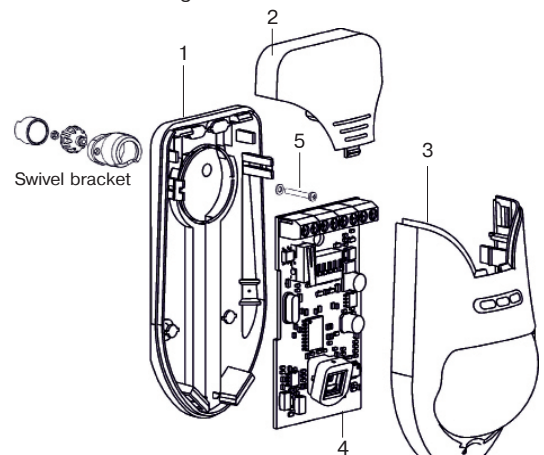

Figure 3 – Design of the Detector

Connection

- Terminals for wire hooking up are located at the top of the PCB.
- Fulfill connections in accordance with Figure 4.

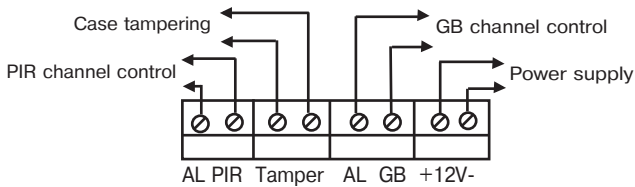

Figure 4 – The Detector connection pattern

- Set operation mode by means of DIP-switches «1», «2», «3», «4» and «5» in accordance with particular application conditions (see Table 2).
- Install the access hole.

Table 2

Mode	DIP-switch	DIP-switch position	
		ON	OFF
GB channel sensitivity	«1»	+14 dB	min
GB sensitivity sensitivity	«2»	+7 dB	min
PIR channel sensitivity	«3»	high	normal
Alarm memory (AM)	«4»	AM	No AM
LED indication	«5»	ON	OFF

LED Indication

LED indication modes are listed in Table 4.

Table 4

Message	Channel	LED color		
		yellow	red	green
Warm-up time		*	+/-	*
Norm		-	-	-
Indication of Interferences	First GB frequency	-	-	++
	Second GB frequency	-	-	+
	PIR	+	-	-
Alarm	GB	-	*	*
	PIR	*	*	-
Alarm memory	GB	-	-/+	+/-
	PIR	+/-	-/+	-
Failure	Power supply	*	- -/+	*

Notation:
 - Indication is OFF;
 ++ double-shot blinkings;
 +/-, -/+ LED is blinking at 1 Hz frequency;
 --/+ LED is blinking at 2 Hz frequency.

* LED is ON;
 + single-shot blinkings;

Switching On and Testing

After energizing the Detector is starting operation in standby mode during 1 min. It is displayed by yellow and green LEDs lighting and red LED indicator blinking at 1 Hz frequency. Green LED indicator switches off in 3 – 5 sec, red and yellow LEDs – in 50 – 57 sec, thus confirming the Detector both channels availability and it's proceeding to the standby mode.

Functional Testing

During operation in standby mode, the Detector generates «Norm» message (by GB and PIR channels relay contacts closing). For correctness of the installation place choice checking, it is necessary to fulfill functional testing of GB and PIR channels.

1) PIR Channel Testing

Get off the detection zone, energize the detector and wait for 1 min before test starting. Make sure that LED indicators are switched off. In presence of interferences (see Table 4), find out and eliminate the cause of it, if it is possible. Moving across the sensing zones at a speed 0.5 – 1 m/sec, define the border of PIR channel detection zone by yellow LED indicator switching on. After it move at speeds 0.3 m/sec and 3 m/sec and check the Detector sensitivity by red and yellow indicators switching on. «Alarm» message is generated after 2 – 4 steps inside the detection zone. If it is necessary, change the zone alignment by turning the Detector on the swivel bracket in vertical or (and) horizontal plane (swivel bracket ensures changing the detection zone position on $\pm 45^\circ$ in horizontal plane and it's tilt angle up to 20° in vertical plane). After it fulfill the detection zone alignment and sensitivity check once more.

2) GB Channel Testing

Set DIP-switches «1» and «2» at OFF position (minimum sensitivity level).

Suspend a steel ball (21.5 ± 0.5) mm in diameter weighting (40 ± 8) g on a 35 cm long thread near the monitored glass standing clear of it, deflect it at an angle of $30 - 70^\circ$ (see Table 4). Deliver a test blow to the remote section of the protected glass. Don't occlude the Detector during blow delivering. If the test blow is not accompanied by green LED indicator two-shot blinking, the Detector sensitivity should

be increased by means of «1» and «2» DIP-switches with further GB testing procedure repetition.

Table 5

Glass thickness, mm	<3	3-4	4-5	5-6	6-7	>7
Ball deflection angle for ordinary, armed and ornamental glass, $^\circ$	30	35	40	45 ^{*)}	50	55
Ball deflection angle for hardened and laminated glass, $^\circ$	45	50	55	60	65	70

*) – Inclination angle for glass blocks

Fulfill the same testing by delivering blows to different places of the other monitored glasses (after each blow green LED indicator should blink twice). If it is necessary, repeat sensitivity adjustment.

Note – For the detector adjustment of sensitivity to impacts on multilayer glass, small-area or double-glass, it is possible to use glass-break simulator.

Alarm Memory Mode

Set the DIP-switch «4» in ON position. In this mode in 5 min after alarm in GB channel and relevant alarm message generation, red and green LEDs alternately blink at a 1 Hz frequency, and in case of alarm in PIR channel – yellow and red LEDs blink at a same frequency. Indication duration is 15 min.

Self-Testing Mode

The Detector fulfills self-testing automatically. During self-testing ambient temperature and power supply voltage value is checked. In ambient temperature range is close to 36°C , PIR-channel detectability is improved (temperature compensation is provided).

If power supply voltage drops lower than 9.1 V , «Failure» message is generated by GB and PIR channels relay contacts opening. The message is repeated by red LED indicator lighting at 1Hz frequency with yellow and green LEDs blinking. The «Alarm» message duration is 15 min.

LED Indicator Disabling

For the Detector operation masking, possibility of indication disabling is provided by setting DIP-switch «5» to OFF position. In this mode indicator operation is provided during 1 min after Detector energizing, as well as in Alarm Memory or Failure modes.

ATTENTION! The Detector must be checked at least annually in order to test it's performance.

Manufacturer's Guarantees

The manufacturer guarantees conformity of the Detector to it's Technical Specifications if provided that the transportation, storage, installation and operation conditions are observed.

The guaranteed shelf life of the Detector is 63 months since the date of manufacture.

The guaranteed useful life is 60 months since the day of putting into operation within the guaranteed shelf life.

The Detectors that are found non-conforming to the Technical Specifications shall be repaired by the manufacturer, provided the installation and operation rules have been complied with.

Storage and Transportation

The Detectors in their original packaging may be transported by any means of transportation in closed vehicles over any distances in compliance with the existing shipping rules concerning the respective means of transportation.

The storage premises should not contain any current-conducting dust, acid and alkali fumes, or corrosive or destroying insulation gases.

The Detectors in transport packaging should be stored no longer, than 3 months. Otherwise they should be released from transport packaging.

Acceptance and Packing Certificate

Combined PIR + glass break detector «Orlan-Sh»,

serial number _____,

has been manufactured in compliance with the active technical documentation and classified as fit for operation and packed by «RIELTA» JSC.

Person in charge of acceptance and packing

QC representative _____ day, year, month