

WIRELESS SECURITY PASSIVE INFRARED WIDE-ANGLE DETECTOR FOR OPEN AREAS

«PYRONE-8-RK»

Installation Guide

1 Product Overview

1.1 Wireless security passive infrared wide-angle detector for open areas «Pyrone-8-RK», (hereinafter, the detector) is designed for detecting intrusion into a protected zone of closed or opened areas, with generation of alarm messages via wireless two-way communication channel within the 433.05 – 434.79 MHz frequency range by the «Rielta-Contact-R» protocol.

The detector is intended to operate as a component of any control panel (hereinafter, CP), supporting the «Rielta-Contact-R» wireless two-way communication protocol.

1.2 The detector radiated power does not exceed 10 mW.

1.3 The detector is powered from two power supply batteries, the main and the backup one CR123A type, located inside the detector case and providing normal operation of the detector for 3 years under normal climatic conditions, if broadcasting period is not less than 60 sec.

1.4 The detector generates and transmits the following messages via radio communication:

- «Norm» – under the other messages absence;
- «Alarm» – if the intrusion to the secured zone is detected;
- «Tamper» – upon the case tampering;
- «Main Power Supply Low-battery» – when the main battery supply voltage drops up to 2.4_{0.4} V and lower;
- «Backup Power Supply Low-battery» – when the backup battery supply voltage drops up to 2.4_{0.4} V and lower.

The detector provides the following indication:

- «Binding» – during the procedure of logging the detector in the CP;
 - «Identification» – by receiving the relevant command from the CP.
- 1.5 The radio exchange is initiated by the detector with the periods: 10, 15, 30 sec, 1, 5, 10 min. The broadcast period is assigned in the process of the detector adjustment. Tamper messages are transferred immediately.

1.6 The detector is provided with:

- three passive infrared channels for detection of the intrusion into protected area;
- two-color (red and green) LED indication for displaying the detector state and communication quality with CP in the place of installation;
- «SENS.HIGH» jumper for the detector sensitivity adjustment;
- «RESET» jumper for the detector changeover to the «Binding» mode;
- case tamper.

1.7 Two frequencies (main and reserve) are used for radio signals exchange between the detector and CP.

Switching to a backup operating frequency in case of an imperfect interference situation at the main one is realized automatically.

1.8 The detector has immunity to:

- pets up to 20 kg movement inside the detection zone;
- background illumination difference impact up to 20 000 lx;
- background illumination change at a rate of 5 °C/min.

1.9 The Detector is resistant to the radio interference.

1.10 The detector design ensures it's normal round-the-clock operation outdoors.

2 Features

The detector has wide-angle detection zone.

The detection zone position can be aligned by means of the swivel bracket. To ensure protection against an atmospheric condensation, the weather shield is provided.

3 Specifications

Table 1

Parameter	Value
Maximum detection range	12 m
Permissible mounting height	2 ... 3 m
Speed detection range	0.3 ... 3 m/sec
Detection field-of-view angle in horizontal plane	90°
Operating temperature	minus 40 ... +55 °C
Permissible relative humidity at 25 °C	up to 100 %
Climatic design	moderately cold climate
IP rating	IP54
Dimensions, max	180 x 70 x 60 mm
Weight, max	0.2 kg
Battery life, not less	8 years
Operation time upon normal climate conditions and preset wireless signal exchange rate 60 sec and more:	5 years

4 Scope of Delivery

The announcer scope of delivery is listed in Table 2.

Table 2

Name	QNT
Wireless security passive infrared wide-angle detector «Pyrone-8-RK»	1 pc.
Weather shield	1 pc.
Swivel Bracket	1 pc.
Antenna	1 pc.
Wall plug NAT 5x25 SORMAT	2 pcs.
Screw 3-3x30.016	2 pcs.
Power supply battery CR123A Plastic potting compound	2 pcs.
Plastic sealer	1.0±0.5 g
Wireless security passive infrared wide-angle detector «Pyrone-8-RK».	1 copy
Installation Guide	

5 Design

The Detector (Figure 1) consists of base (1), PCB (3) and cover (6).

The PCB contains: two power supply battery CR123A holders (the main (5) and the backup (4)), three infrared pyrodetectors (9), antenna (10) (supplied), two-color LED indicator (11), tamper (12), jumper and contacts «SENS HIGH» (13), «RESET» contacts (14).

Swivel bracket (1) and weather shield (2) are available. The PCB is fixed on the base by means of latch (15) and screw (8).

The cover (6) is fixed to the base (1) by four screws (7) with a sealing gasket.

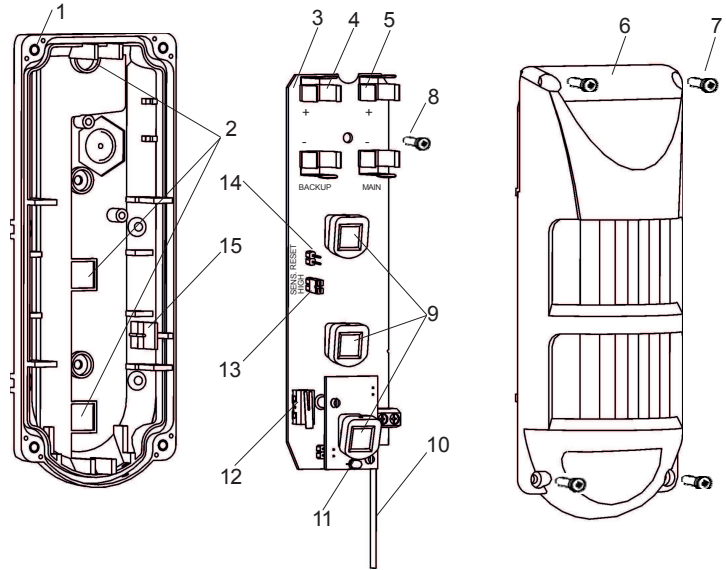

Figure 2

6 Binding with the CP

6.1 The binding procedure is intended for logging of the Detector in the CP and the transmission of service information to it. Prepare the CP for the Detector binding in compliance with the CP Installation Guide.

6.2 Install first the backup power supply battery, and after the main one into the holders, located on the PCB (if the battery is installed by manufacturer, remove an isolator).

6.3 The LED indicator blinking green displays the detector readiness for the binding procedure. In case the LED indicator does not blink, close the «Reset» contacts for a short time period using any metal object.

6.4 After a successful binding with the CP, the LED indicator lights red for 2 sec.

6.5 The detector operation in the «Binding» mode is limited to 100 sec. After the time is up, the detector changes to the sleep mode. To resume the «Binding» mode, the «RESET» contacts must be closed for a moment.

7 Choosing the Installation Place

The detection zone (see Figure 2) should reliably cover overall controlled area. The detector should be installed at the height (2.3 ± 0.1) m. Take note of the fact, that the detection zone should not be limited by non-transparent objects (branch of trees and bushes, plants, mesh fences, etc). There must be no items exposed to the temperature jumps within the detector visibility zone (such as sun-heated wals and wall-parts).

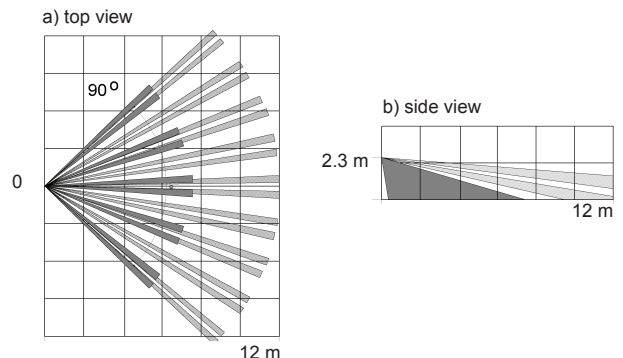

Figure 2 – Detection Pattern

The communication quality with the CP at the place of the detector installation should provide reliable message transmission (See Cl. 9 Communication Quality Appraisal).

8 LED Indication

Table 3

Detector Status	LED Indication	
	LED Status	Operation mode
«Binding»	Green LED indicator blinks intermittently	
«Alarm»*	LED indicator lights red for at least 0.5 sec	If indication is enabled
«Identification»	LED indicators blinks alternately red and green at 1 Hz frequency	by a command from the CP
«Connection quality»	See Sect. «Communication Quality Appraisal»	
Binding procedure completed	LED indicator lights red for 2 sec	

*) – Alarm indication is deactivated in 15 minutes after the detector cover is closed and activated after it has been opened or at a command from the CP.

9 Communication Quality Appraisal

Before installing the detector, it is advisable to check the Detector communication quality with the CP. In this regard:

1. Prepare the detector for operation and put it on its place of operation with a closed cover;
2. Open the detector case, whereupon the detector will indicate the quality of communication with CP.

Table 4

LED Indication	Communication Quality Appraisal	Recommendations
LED indicator blinks green three times	Excellent	Install the detector at this place
LED indicator blinks green two times	Good	
LED indicator blinks green one time	Communication established	Choose another place for installation or use a repeater*)
LED indicator blinks red four times	No communication	

*) – «Ladoga-RK» system repeater

10 Installation

10.1 Assemble the supplied swivel bracket:

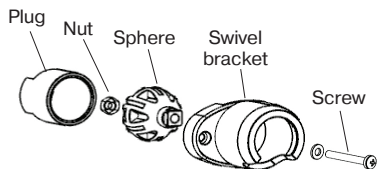

Figure 3 – The Swivel Bracket Design

- place the screw-nut into the sphere recess;
- enclose the swivel bracket base into the sphere;
- insert the plug into the swivel bracket base.

10.2 Install and fix the assembled swivel bracket to the wall/ceiling at the chosen place of installation. The swivel bracket case should be used as a pattern for marking fixation holes on the installation surface.

10.3 Fix the base to the installed swivel bracket by means of mounting screw passing it through the one of the openable holes (2).

10.4 After fixing the base on the swivel bracket pack off the opening (2) by the plastic potting compound (supplied).

10.5 Put the PCB on it's place, fix it by latch and screw (8).

10.6 Connect antenna (10) to the PCB through the hole in the Detector base.

10.7 Put on the Detector cover and turn its case in the chosen direction.

11 Adjustment

11.1 The detector adjustment includes the detection zone position alignment and sensitivity level choosing.

11.2 To determine the limits of the detection zone, start movement across the detection zone at a speed of 0.5 – 1 m/sec 60 sec after switching the detector in «Activated» mode.

11.3 Upon every detection of a movement, the detector transmits the «Alarm» message via radio communication. During the first 15 min after the cover closing, the «Alarm» message is duplicated by the LED indicator switching red in a short-run.

11.4 Changing of the detection zone position is fulfilled by the detector rotation on the swivel bracket.

«Alarm» message generation upon the motion absence within the detection zone limits indicates a high - interference environment. In this case, it is recommended to narrow the detector sensitivity. Removal of «SENS.HIGH» jumper reduces the detector detection range from 12 up to 8 m, but in the same time it increases the detector interference protection. After sensitivity adjustment, check the detection zone limits.

The «Alarm» indication is switched off automatically in 15 min after the detector case closing.

If it is necessary to continue the adjustment, put off the cover, and after put it on it's place.

Modes of operation

The detector provides three modes of operation: «Deactivated», «Activated» and «Identification». The modes changeover is ensured by the relevant command from the CP.

Under operation in the «Deactivated» mode, the detector transmits the «Alarm» message immediately with contemporary starting unscheduled radio communication session. «Norm» message is transmitted during regular radio communication sessions.

Under operation in the «Activated» mode, the detector immediately transmits messages about it's state changing with contemporary starting unscheduled radio communication session.

Under the «Identification» mode, started by the relevant command from the CP, the LED indicator blinks red and green alternately (See Table 3). The «Identification» mode allows to locate the detector with the preset address.

12 Storage and Transportation

12.1 The detector are transported without power supply battery. The detector in their original packaging are resistant to:

- transport jolting with the acceleration up to 30 m/sec² at impact frequency range from 10 to 120 per minute or 15 000 strikes;
- ambient temperature range minus 50 ... +50 °C;
- relative air humidity (95 ± 3) % at a temperature +35 °C.

12.2 The detector in original package may be transported by any means of transportation in closed vehicles over any distances in compliance with the existing shipping rules concerning the respective means of transportation.

12.3 After transportation under the conditions different to exploitation conditions the detector shall be ready to operate after a maximum of six hours.

12.4 The storage room shall be free from current-conducting dust, acid vapors, alkali and gases that cause corrosion and destroy insulation.

13 Manufacturer's Guarantees

13.1 The manufacturer guarantees conformity of the Detector to the Technical Specifications requirements provided the transportation, storage, installation and operation conditions are observed.

13.2 The guaranteed shelf life of the Detector is 63 months since the date of manufacture.

13.3 The guaranteed useful life is 60 months since the day of putting into operation within the guaranteed shelf life.

13.4 The Detectors that are found non-conforming to the Technical Specifications requirements shall be repaired by the manufacturer, provided the installation and operation rules have been complied.

Note – Warranty obligations are not applied to the power supply batteries.

14 Packing Certificate

Wireless security passive infrared wide-angle detector «Pyrone-8-RK» has been manufactured in compliance with the active technical documentation, classified as fit for operation and packed by «RIELTA» JSC.

Packing date _____
month, year