



# RiDom

## Temperature detector «Ri-TD-1»



Installation guide

### 1 GENERAL INFORMATION

1.1 The temperature detector «Ri-TD-1» (hereinafter referred to as the Detector) monitors the air temperature and transmits digital readings via a two-way radio channel in accordance with the «Ri-Contact-R» protocol.

1.2 The Detector works as part of the RiDom smart home security system, communicating with the «Ri-HUB-1» control center (hereinafter referred to as the Hub) using the «Ri-Contact-R» radio channel protocol.

1.3 The Detector does not require licensing and registration as a radio transmission product.

1.4 Two frequencies – the main and the backup – are used for the exchange of radio signals between the Detector and the Hub. The transition to the backup frequency happens automatically.

1.5 The ambient temperature range is set at the factory: from -55 °C to +125 °C. The boundaries of the controlled range are stored in the non-volatile memory of the Detector and can be changed by a command from the Hub. When the air temperature goes beyond the controlled range, an «Alarm» notification is generated.

1.6 The Detector transmits the following notifications over the radio channel:

- the normal status – when the temperature is within the specified range;
- alarm – when the temperature exceeds the specified range by 0,5 °C or more;
- opening of the case;
- battery discharge;
- «Linking» mode;
- «Identification» mode;
- quality of communication.

1.7 The Detector is designed for continuous round-the-clock operation.

1.8 The Detector is resistant to electromagnetic interference.

### 2 SPECIFICATIONS

Table 1

Parameter	Value
Frequency range	868,7...869,2 MHz
Radiation power, no more	25 mW
Temperature measurement accuracy in the operating range	± 1 °C
Protection class	IP30
Battery type	CR123A, 1 pc.
Duration of operation of the Detector from the battery under normal climatic conditions and a set period airing of 60 seconds	36 months
Dimensions	97x25x22 mm
Weight	50 g
Average service life	8 years
Operational conditions	
Operating temperature range	-20... +55 °C
Permissible air humidity at a temperature of +25 °C, without moisture condensation	Up to 98 %

### 3 SCOPE OF SUPPLY

Table 2

Name	Qty.
Temperature detector «Ri-TD-1»	1 pc.
Screw 3-3x30.016	2 pcs.
Lithium battery CR123A	1 pc.*
Installation guide for the «Ri-TD-1»	1 copy
* Included	

### 4 VIEW AND DESIGN

The Detector consists of a case cover and a case base with a mounted printed circuit board (1).

The following elements are located on the printed circuit board:

- built-in temperature sensor (2);
- RESET contacts (3);
- opening sensor (4);
- battery holder (5);
- battery (6) with insulator (7);
- red and green LED indicators (8);
- antenna (10).

The board is fixed in the base of the case with a latch (9).

There are mounting holes on the base of the case in the lower part (11) and in the side wall (13).

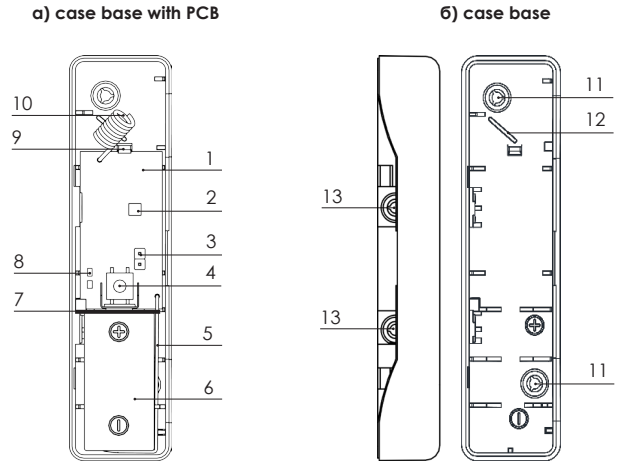

Picture 1 – «Ri-TD-1» detector case

### 5 INDICATION

The Detector generates the following types of indication:

- the «Linking» mode indication (registration of the Detector in the Hub);
- the «Identification» indication turns on upon receipt of the appropriate command from the Hub and remains active for 15 minutes or until the case is opened;

Indicator modes are listed in Table 3.

Table 3

Detector status	Indication	Notes
«Linking» mode	Turning on the green indicator with a period of 1 s	Registration of the Detector in the Hub
Completion of «Linking»	Turning on the red indicator for 2–3 s	
«Channel 1 alarm» «Channel 2 alarm»	Periodic turning on of the red indicator with a period of 8 s	With case closed
«Identification» mode	Alternately turning on the red and green indicators	Received the corresponding command from the Hub
Connection quality assessment	See «Connection quality assessment» paragraph	
«Normal»	Off	

### 6 CHOOSING THE PLACE OF INSTALLATION

The Detector should be installed indoors only. When choosing a place for installation of the Detector, consider the presence of obstacles that can weaken the transmission of the radio signal.

The Detector is intended for indoor installation only.

**DO NOT install the Detector if the following cases:**

1. In close proximity to electrical wiring.
2. Near metal objects and mirrors that cause attenuation of the radio signal or shield it.
3. Outdoor.

### 7 CONNECTING THE DETECTOR TO THE SYSTEM

7.1 Open the RiDom application and click **+** in the My Devices tab. Then press **Add device** button. Select the «Ri-TD-1» detector from the list of devices and follow the prompts in the application.

7.2 Open the case by pressing the latch with a screwdriver.

7.3 When prompted by the application, remove the battery isolator.

7.4 The Detector will periodically turn on the green LED, which indicates that it is in the «Linking» mode. In the absence of the indication, interconnect the «RESET» contacts for 2-3 seconds.

7.5 Upon successful connection to the Hub, the indicator on the sensor will turn red for 2-3 seconds, then you can see the Detector in the application, as well as all the information about it. The «Linking» mode time is limited to 100 seconds. To resume the mode, it is necessary to briefly interconnect the «RESET» contacts.

7.6 Install the case cover back.

## 8 CONNECTION QUALITY ASSESSMENT

8.1 To assess the quality of radio communication between the Detector and the Hub, it is recommended to do the following:

- place the Detector in the intended installation location;
- press and release the case opening sensor.

8.2 When the case opening sensor is released, the Detector generates a case opening notification, transmits it via a radio channel and displays the quality of radio communication with the Hub in accordance with Table 4.

Table 4 - Indication of the communication quality control results

Indication		Connection quality	Recommendations
Color	Mode		
Green	Three blinks	Perfect	Installation in this location is allowed
Green	Two blinks	Good	
Green	One blink	Weak	Choose a different installation location or use a repeater
Red	Four blinks	No connection	

## 9 INSTALLATION

To install the Detector, remove the cover and take out the printed circuit board. The cover is fixed to the base with latches.

To remove the printed circuit board, press the latch (9) (Picture 1a) at the base of the housing.

Prepare holes for mounting the Detector. The Detector base can be used for marking the holes.

Fix the base with screws. Install PCB, battery.

Install the cover.

### Dimensions (mm)

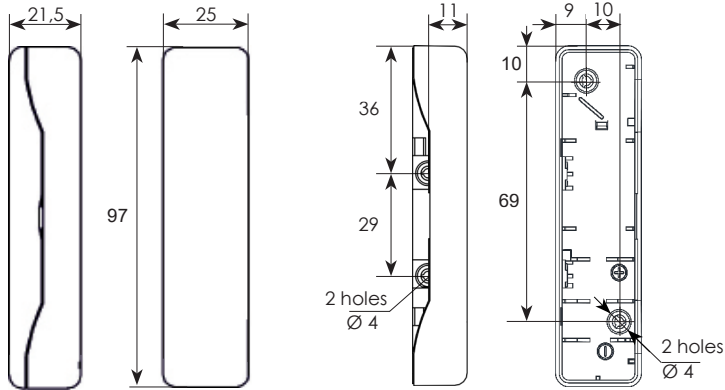

Picture 2 – Overall dimensions

## 10 STORAGE AND TRANSPORTATION

10.1 The Detectors in their original packaging are resistant to:

- transport jolting with the acceleration up to 30 m/sec<sup>2</sup> at impact frequency range from 10 to 120 per minute or 15 000 strikes;
- ambient temperature range minus 50 ... +55 °C;
- relative air humidity (95 ± 3) % at a temperature +35 °C.

10.2 The Detectors in original package may be transported by any means of transportation in closed vehicles over any distances in compliance with the existing shipping rules concerning the respective means of transportation.

10.3 After transportation under the conditions different to exploitation conditions the Detectors shall be ready to operate after a maximum of six hours.

10.4 During storage period lithium batteries should be removed from the holders or isolators should be installed.

**Note:** The storage premises should not contain any current-conducting dust, acid and alkali fumes, or corrosive or destroying insulation gases.

## 11 DISPOSAL INFORMATION

11.1 The Detector does not contain precious metals, hazardous or toxic substances that can harm human health or the environment, and does not pose a danger to life, human health and the environment at the end of its service life.

11.2 In this regard, the disposal of the Detector can be carried out according to the rules for the disposal of general industrial waste.

11.3 Dispose the batteries by handing over the used batteries to a trade organization, a service center, an equipment manufacturer or an organization that accepts used batteries.

## 12 MANUFACTURER WARRANTY

12.1 LLC NPP RIELTA guarantees that the Detector meets the requirements of technical specifications within 27 months from the date of manufacture, subject to the conditions of transportation, storage, installation and operation.

12.2 Warranty period of operation of the Detector is 24 months from the date of commissioning within the warranty period of storage.

12.3 If during the warranty period the Detector, which is subject to the rules of transportation, installation and operation, is found to be inconsistent with the requirements of the technical specifications, it is to be replaced or repaired by the manufacturer.

**Note** – Lithium batteries are not covered by the warranty

## 13 DATE OF MANUFACTURE

\_\_\_\_\_ month, year



ridom.ru

Made in Russia

v10/v14