



RiDom

Dual-channel temperature detector «Ri-TD-2»



Installation guide

1 GENERAL INFORMATION

1.1 The dual-channel temperature detector «Ri-TD-2» (hereinafter referred to as the Detector) is designed to measure temperature and transmit values as well as to control the determined range with subsequent transmission of notifications in case the temperature changing above or below the set boundaries over a two-way radio channel in accordance with the protocol «Ri-Contact-R».

1.2 The Detector operates as part of the RiDom smart home security system, communicating with the «Ri-HUB-1» control center (hereinafter referred to as the Hub) via the «Ri-Contact-R» wireless protocol.

1.3 The Detector does not require licensing or registration as a radio frequency device.

1.4 Two frequencies – the main and backup – are used to exchange radio signals between the Detector and the Hub. The transition to the backup frequency is automatic.

1.5 The Detector has two channels for temperature measurement and control. Channel 1 – built-in temperature sensor (hereinafter referred to as built-in TS). Channel 2 – external temperature sensor (hereinafter referred to as external TS).

1.6 The Detector can be added to the system in a two-channel operating mode or in a single-channel mode. In the second case, the status of the remote TS will be ignored. The mode is selected at the stage of registering the sensor in the Hub.

1.7 The temperature range limits (low – plus 17 °C, high – plus 27 °C) set by the manufacturer are stored in the non-volatile memory of the Detector and can be changed by the corresponding command from the Hub for each channel separately.

1.8 The Detector generates and transmits the following notifications via radio channel:

- «Normal» – when the temperature is within the specified range;
- «Alarm in channel 1» – when the temperature in channel 1 goes beyond the specified range by 1° or more;
- «Alarm in channel 2» – when the temperature in channel 2 goes beyond the specified range by 1° or more;
- «Opening» – when the case is opened or the detector is removed from the mounting surface;
- «Fault in channel 1» – if there is a malfunction of the built-in TS in channel 1;
- «Fault in channel 2» – in case of a malfunction or disconnection of the remote TS in channel 2;
- «Battery low» – when the battery voltage drops below 2.2-0.2 V.

1.9 The Detector is designed for continuous round-the-clock operation.

1.10 The Detector is resistant to electromagnetic interference.

2 TECHNICAL SPECIFICATION

Table 1

Parameter	Value
Frequency range	868.7...869.2 MHz
Radiation power	25 mW
Temperature measurement error, no more than:	
- in the temperature range from minus 10 to +85 °C	± 1.0°C
- in the temperature range from minus 55 to minus 11 °C and from +86 to +125 °C	± 2.0°C
Degree of protection provided by the enclosure:	
- detector	IP30
- remote TS	IP65
Battery type	CR123A
Duration of operation of the Detector from a battery under normal climatic conditions and with a set broadcast period of 60 s, not less	36 months
Dimensions	112x41x32 mm
External TS cable length	10 m
Weight	0.1 kg
Average service life	8 years
Operational conditions	
Operating temperature range :	
- Detector	-20... +55 °C
- remote TS	-55... +125 °C
Permissible air humidity at a temperature of +25 °C, without moisture condensation	Up to 98 %

3 CONTENTS OF THE KIT

Table 2

Name	Qty.
Dual-channel temperature detector «Ri-TD-2»	1 pc.
Screw 3-3x30,016	2 pcs.
Lithium battery CR123A	1 pc.*
Remote temperature sensor	1 pc.
Installation guide for the «Ri-TD-2»	1 copy
* Included	

4 DESIGN

The Detector consists of the following elements: case cover, case base and printed circuit board.

The cover is fixed to the base (1) with latches located at its ends. To release the cover, press the latches with your fingers.

On the front side of the printed circuit board (2) there are: a tamper switch (3), a two-color LED indicator (4), a terminal contacts block for connecting an external TS (5), a holder (6) for installing the main battery, «RESET» contacts (8), built-in DT (9), piezo sound emitter (10), antenna (11). The lift-off sensor is located on the back of the printed circuit board. The board is fixed in the base of the case with a latch (7) and hooks on the opposite side of the base.

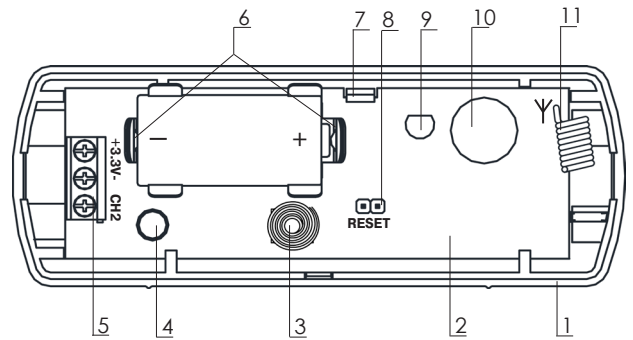

Picture 1 – «Ri-TD-2» view with removed case cover

5 INDICATION

The Detector generates the following types of indication:

- «Linking» mode (registration of the Detector in the Hub);
- «Identification» – turns on when the corresponding command is received from the Hub and remains for 15 minutes or until the case is opened;
- light indication of the Detector status turns on and is saved in the first 15 minutes after closing the case in the absence of other types of indication (except for sound), provided that during this time the «Opening» notification is not generated or a command from the control panel to prohibit the indication is not transmitted;
- sound indication of the sensor status turns on when the corresponding command is received from the control panel.

The modes for turning on the indicators are listed in Table 3.

Table 3

Detector status	Indication	Comments
Ending the «Linking» mode	Turning on the red indicator for 2-3 s	
«Linking» mode	Turns on the green indicator with a period of 0.25 s	Registering a Detector in the Hub in single-channel mode
	Turns on the green indicator with a period of 1 s	Registering a Detector in the Hub in dual-channel mode
«Identification» indication	Alternately turning on the indicator light in red and green colors	The corresponding command has been received from the Hub
«Alarm in channel 1» «Alarm in channel 2»	Single turning on of the red indicator light with a period of 4 s*	Status indication is on and «Identification» indication off
Initiation «Alarm in channel 1» «Alarm in channel 2»	Turning on the sound indicator twice**	Audio status indication enabled
Recovery after «Alarm in channel 1» «Alarm in channel 2»	One-time activation of the sound indicator**	
Connection quality assessment	See section «Connection quality assessment»	
«Fault in channel 1» «Fault in channel 2»	The orange indicator light turns on twice with a period of 12 s	Status indication is on and «Identification» indication is off
«Normal»	OFF	
* Light indication of Detector status		
** Sound indication of Detector status		



6 CHOOSING PLACE OF INSTALLATION

When choosing a location for installing the Detector, take into account the presence of obstacles that impair the passage of the radio signal.

DO NOT install the detector in the following cases:

1. In close proximity to electrical wiring.
2. Near metal objects and mirrors that cause attenuation of the radio signal or shield it.

7 CONNECTING THE DETECTOR TO THE SYSTEM

7.1 Open the RiDom application. In the «My Devices» tab, click  and then . Select the «Ri-TD-2» Detector from the list of devices and follow the application prompts.

7.2 Remove the cover by releasing the latches.

7.3 When prompted in the app, remove the battery isolator.

7.4 The Detector will periodically turn on the green indicator, which shows that it is in the «Linking» mode. If there is no indication, close the «RESET» contacts for 2-3 seconds.

7.5 When successfully connected to the Hub, the indicator on the Detector will turn red for 2-3 seconds, then you will be able to see the Detector in the application, as well as all data about the Detector. The Linking mode time is limited to 100 seconds. To resume the «Linking» mode, it is necessary to briefly close the «RESET» contacts.

7.6 Install the case cover back.

8 CONNECTION QUALITY ASSESSMENT

8.1 To assess the quality of radio communication between the Detector and the Hub, you should:

- place the Detector in the intended installation location;
- press and then release the release the tamper switch.

8.2 When the tamper switch is released, the Detector generates a notification about the case tampering, transmits it via radio channel and displays the quality of radio communication with the Hub in accordance with Table 4.

Table 4 – Indication of the communication quality control results

Indication		Connection quality	Recommendations
Color	Mode		
Green	Three blinks	Perfect	Installation in this location is allowed
Green	Two blinks	Good	
Green	One blink	Weak	
Red	Four blinks	No connection	Choose a different installation location or use a repeater

9 INSTALLATION

To install the Detector, remove the case cover and remove the printed circuit board. The cover is fixed to the base with latches. To remove the printed circuit board, press the latch (7) (see Picture 1) at the base of the case.

Prepare holes for mounting the Detector. The base of the Detector can be used for marking the holes (see Picture 2).

Secure the base with screws. To control the separation from the wall, screw the second screw into the clamp of the sensor of the separation from the wall.

Install the printed circuit board and, if necessary, connect an external TS to the terminal block in accordance with Picture 3.

Install the case cover back.

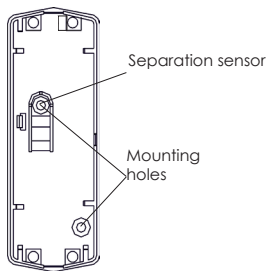

Picture 2 – Detector base

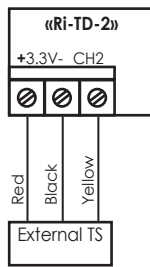

Picture 3 – Connection diagram for remote TS to Detector

10 STORAGE AND TRANSPORTATION

- 10.1 The Detectors in their original packaging are resistant to:
- transport jolting with the acceleration up to 30 m/sec² at impact frequency range from 10 to 120 per minute or 15 000 strikes;
 - ambient temperature range minus 50 ... +55 °C;
 - relative air humidity (95 ± 3) % at a temperature +35 °C.

10.2 The Detectors in original package may be transported by any means of transportation in closed vehicles over any distances in compliance with the existing shipping rules concerning the respective means of transportation.

10.3 After transportation under the conditions different to exploitation conditions the Detectors shall be ready to operate after a maximum of six hours.

10.4 During storage period lithium batteries should be removed from the holders or isolators should be installed.

Note: The storage premises should not contain any current-conducting dust, acid and alkali fumes, or corrosive or destroying insulation gases.

11 DISPOSAL INFORMATION

11.1 The Detector does not contain precious metals, hazardous or toxic substances that can harm human health or the environment, and does not pose a danger to life, health and the environment at the end of its service life.

11.2 In this regard, the Detector can be disposed of in accordance with the rules for the disposal of general industrial waste.

11.3 Dispose of batteries by handing over the used batteries to a trading organization, service center, equipment manufacturer or organization that accepts used batteries and batteries.

12 MANUFACTURER WARRANTY

12.1 LLC NPP RIELTA guarantees that the Detector meets the requirements of technical specifications within 39 months from the date of manufacture, subject to the conditions of transportation, storage, installation and operation.

12.2 Warranty period of operation of the Detector is 36 months from the date of commissioning within the warranty period of storage.

12.3 If during the warranty period the Detector, which is subject to the rules of transportation, installation and operation, is found to be inconsistent with the requirements of the technical specifications, it is to be replaced or repaired by the manufacturer.

Note – Lithium batteries are not covered by the warranty.

13 DATE OF MANUFACTURE

_____ month, year



riodom.ru

Made in Russia

v10.1