

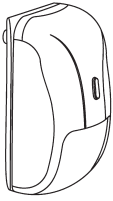

PASSIVE INFRARED DETECTOR



«FOTON-12B»



Installation Guide

General Information

Passive infrared detector «Foton-12B» (hereinafter, the detector) is intended for detecting intrusion into the indoor protected area and generating an alarm message by opening the relay output contacts.

The detector ensures case tamper protection. The «Tamper» message is generated by opening microswitch contacts.

The detector is resistant to the impact of ambient light and radio interference. The detector ensures pet immunity to small animals: mice, rats, birds in cages at a distance not less than 2.5 m.

The detector is attractive, easy to operate and maintain.

It is possible to install the detector on the wall, in the corner of the room or on the ceiling.

Features

- Dual-element pyrodetector.
- Vertical curtain detection zone.
- Microprocessor-based signal processing.
- Possibility of LED indication disabling.
- Case tamper protection.
- Immunity to insects intrusion to the pyrodetector.
- Temperature compensation of detectability.
- Is rated for switching to the DC power source with output voltage 9 ... 15 V.
- Swivel bracket supplied.

Specifications

Table 1

Parameter	Value
Maximum detection range in speed range 0.3 – 3 m/sec, max	15 m
Permissible installation height	2 – 3 m
Output relay contacts	30 mA, DC 72 V
Alarm message duration	Not less than 2 sec
Power supply	9 ... 15 V DC
Operating temperature	from minus 30 to +55 °C
Relative humidity at +25 °C	Up to 98 %
Detection zone angle in horizontal plane	100°
IP rating	IP41
Dimensions, max	92 x 57 x 48 mm
Weight, max	100 g
Average service life, not less than	8 years

Scope of Delivery

Each Detector unit package contains the items listed in Table 2.

Table 2

Name	QNT.
Passive infrared detector «Foton-12B»	1 pc.
Swivel bracket	1 pc.
Screw 3-3x30.016	2 pcs.
Passive infrared detector «Foton-12B». Installation Guide	1 copy

Choosing the Place of Installation

The Detector is designed for operation in the closed areas. When choosing the Detector installation place, take note of the fact that the detection zone may be limited by non-transparent objects (curtains, houseplants, cabinets, bookcases, etc.), as well as glass and mesh partitions. There must be no windows, air conditioners, space heaters or heating radiators in the Detector visibility range.

When installing the detector, complete it's positioning in such a way, that the expected paths of intrusion would cross the sensitivity zones of the detector.

Alarm loop wires should be located far enough from power feed cables.

Detection Pattern

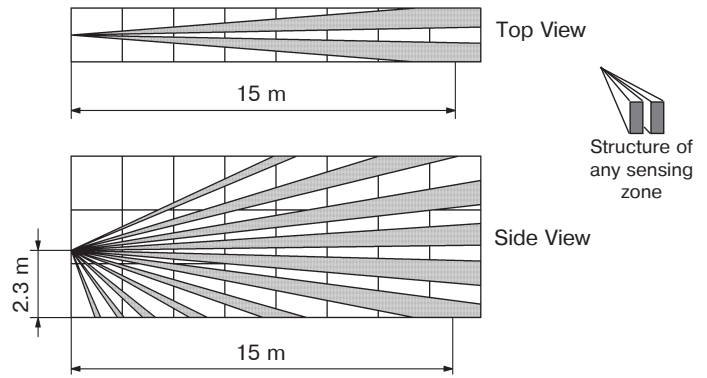

Figure 1

LED Indication

LED indication modes are listed in Table 2.

Table 2

Message	LED Indication Mode. Action Time
«Warm-up Time»	Blinking during 45 sec at 1 Hz frequency after the detector enegizing
«Normal»	No LED indication
«Alarm»	LED is ON for 3 sec
Detection Zones Determination	Switching on for 0.25 sec at each detection zone beam crossing. The mode duration – 5 min after «Warm-up Time» mode in case of ZONE jumper application
«Failure»	Two-flash lighting with 4 sec period

It is possible to disable the LED indicator by removal of the the jumper IND on the PCB.

Installation

- Unfasten the latch at the underside of the detector case by means of screwdriver and remove the detector cover (Figure 2).

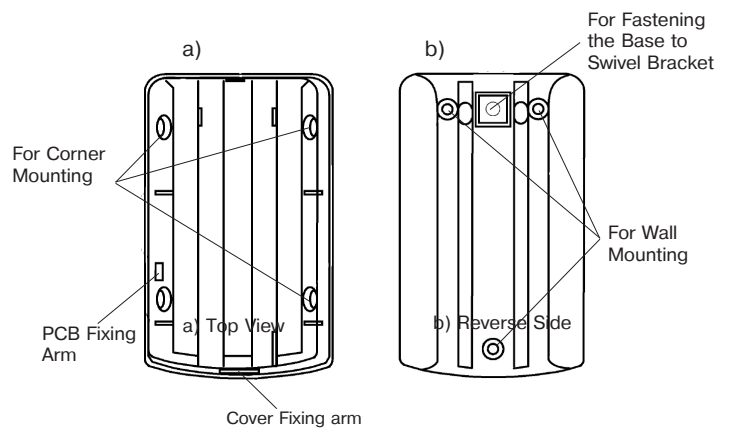

Figure 2 – Base

- When installing the detector without swivel bracket it is necessary to put off the PCB.

- Drill the holes in the base of the detector (Figure 2) for wires installation and for the detector fastening.

- Choose the place of installation, mark the places for mounting holes with the regard to detector base (or swivel bracket) openings, drill the holes in the wall.

- Pull the wires through the mounting holes in the base. Leave several centimeters of wire for it's fastening inside the case.

- Fix the base of the detector at the chosen place. In case of mounting on the swivel bracket (Figure 3), unscrew the cap screw (M3x20 available) from the swivel bracket sphere. Keeping hold the swivel bracket assembled, fit the square bulge of the swivel bracket external sphere with the corresponded opening on the detector base. Plug in the screw into the opening in the top of the detector base and fix the connection by the screw with the forcing, ensuring the base rotation about the swivel bracket.

- Install PCB on it's place, if it was removed.

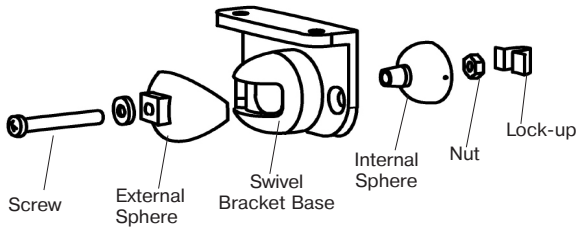

Figure 3 – Swivel Bracket Components

Connection

The terminals for the detector connection are located at the PCB top. Fulfill connections in accordance with the:
 - Figure 4 a) for connection to single alarm loop;
 - Figure 4 b) with tamper control connection to a singular loop.
 Put the cover on it's place.

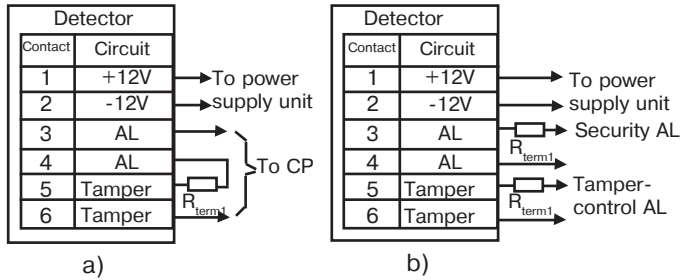

Figure 4

Functional Testing

After the detector energizing wait for 45 sec before functional testing performance. Upon the «Warm-up time» mode expiry, the detector turns to standby mode, and is ready for alarm message generation.

The detection zone high filled density ensures to detect intruder moving both in «full length» and in «flexed» position.

Sensitivity Appraisal and Adjustment

Jumper in ALARM position.

This mode is intended for the detector sensitivity estimation (the travel length from the moment of detection till alarm message generation). The alarm message should be generated after 2 – 4 steps within the detection zone for 3 sec period.

Wait for 8 – 10 sec after each alarm until the LED is off and continue walking across the detection zone.

Note – If the detector fails to detect moving objects in the detection zone, it's position on it's swivel bracket should be changed.

Testing Mode

Jumper in ZONE position.

This mode is intended for the each beam of the detecting zone positioning. In case of each beam crossing, the LED indicator switches for 0.25 sec. Optimal travel speed at maximum detection range – 0.5 m/sec.

Note – In this mode there is no LED indication of alarm message generated by relay contacts opening.

Under the movement absence in the secured zone, the LED indicator should not light. After 5 min testing the detector turns to normal operation mode (in case of ZONE and IND jumpers applied the alarm message generation is displayed by LED indicator lighting for 3 sec period).

LED Indicator Disabling

For the LED indicator disabling after the detector testing, remove the IND jumper. Set the jumper over one of it's pins for the further usage during testing.

Self-testing and Failure Indication

The detector carries out self-testing automatically, processing the ambient temperature.

If the ambient temperature range is related to the human temperature, the sensitivity threshold shift takes place, whereupon the detectability upgrades.

The detector is generating the «Failure» message during 15 min under ambient temperature rise over maximum allowed value by relay contacts opening repeated by periodical doubled LED indicator blinking.

Removal the jumper from ZONE position results in the LED indication reset.

ATTENTION! Detectors «Foton-12B» must be checked at least annually in order to test their performance.

Transportation and Storage

The detectors in original transportation package may be transported by any means of transportation in closed vehicles (railway wagons, closed motor vehicles, sealed and heated airplane compartments, vessel holds, etc.) over all distances.

When transporting the detectors, the rules and regulations applicable to various means of transportation must be adhered.

Storage premises must not contain any current-conducting dust, acid and alkali fumes, as well as corrosive gases or those destroying insulation.

Manufacturer's Guarantees

The manufacturer guarantees conformity of the detector to the requirements of specifications provided the transportation, storage, installation and operation conditions are observed.

The guaranteed shelf life of the detector is 63 months since the date of manufacture. The guaranteed useful life is 60 months since the day of putting into operation within the guaranteed shelf life.

The detector that is found non-conforming to the requirements of specifications should be repaired by the manufacturer.

Packing Certificate

Passive infrared detector «Foton-12B» has been manufactured in compliance with the active technical documentation and classified as fit for operation and packed by «Development and Production Enterprise RIELTA» LLC.

Packing date _____
 month, year