

WIRELESS FLOOD DETECTOR «STZ-RK»

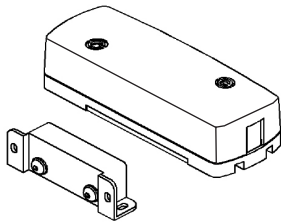

Installation Guide

1 Product Overview

1.1 Wireless flood detector «STZ-RK» (hereinafter, the Detector) is intended for detecting leaks of water, water solutions, other current-conducting non-aggressive liquids and generating an alarm message via a two-way communication by the «Rielta-Contact-R» protocol. The Detector is intended to operate as a component of any control panel (hereinafter, CP) supporting the wireless exchange protocol «Rielta-Contact-R».

1.2 The Detector comprises a Signal Processing Module (SPM) and flood sensors «DZ-3V» (FS). The SPM has two connecting blocks for FS hooking up: «G 1» and «G 2». Not more than two FSs can be hooked up in parallel to each loop.

1.3 The Detector is able to operate in two-loop or single-loop mode. The last mode presumes the «G 2» status is ignored. The operation mode choosing is available during the detector logging in the CP.

1.4 Radio signals are exchanged within the 433.05 to 434.79 MHz frequency range. The transmitter output power does not exceed 10 mW.

1.5 Two operating frequencies: main and reserve are used for the wireless data exchange. The Detector switches over reserve operating frequency automatically.

1.6 Radio exchange sessions are initiated by the Detector at a preset frequency. The frequency settings are 10, 15, 30, 60, 120, 300 or 600 sec, chosen in the process of the binding procedure. The SPM transmits alarm messages to the CP immediately.

1.7 The Detector is powered by a CR123A lithium battery.

1.8 The Detector generates and transmits the following messages:

- «Norm in Loop 1» – under the absence of liquid between the FS contacts plugged to «G 1»;
- «Norm in Loop 2» – under the absence of liquid between the FS contacts plugged to «G 2»;
- «Alarm in Loop 1» – under the presence of liquid between the FS contacts plugged to «G 1»;
- «Alarm in Loop 2» – under the presence of liquid between the FS contacts plugged to «G 2»;
- «Tamper» – when opening the case of the SPM alarm;
- «Failure in Loop 1» under the break of communication bus SPM – FS, hooked to «G 1»;
- «Failure in Loop 2» under the break of communication bus SPM – FS, hooked to «G 2»;
- «Low Battery» – under the power supply battery voltage drop over 2.3_{0.3} V.

1.9 The Detector is designed to operate continuously, around the clock.

1.10 The Detector provides immunity to electromagnetic interference.

1.11 The level of industrial interference generated by the Detector does not exceed the norms established for the technical equipment operated in residential buildings or connected to power mains of residential buildings.

2 Features

Table 1

Parameter	Value
Assumed number of FSs in an alarm loop circuit, max	2 pcs.
Length of each alarm loop between the FS and the SPM, max	5 m
Operating temperature	minus 20 ... +55 °C
Permissible relative humidity at +25 °C temperature	up to 98 %
IP rating: - SPM - FS	IP30 IP67
Case dimensions: SPM, max FS, max	112 x 41 x 32 mm 65 x 22 x 16 mm
Weight: - SPM, max - FS, max	0.1 kg 0.03 kg
The duration of operation of the alarm from a lithium battery in normal climatic conditions and with a set broadcast period of 60 seconds, at least:	60 months
Average service life	8 years

3 Scope of Delivery

Each Detector unit package contains the items Table 2.

Table 2

Name	QNT.
Signal processing module «STZ-RK SPM»	1 pc.
Flood sensor «DZ-3V»	2 pcs.
CR123A lithium power supply battery	1 pc.*
Set of accessories:	
Screw 3-3x30.016	6 pcs.
Nylon wall plug NAT 5x25 SORMAT	6 pcs.
Wireless flood detector «STZ-RK». Installation Guide	1 copy
*Included	

4 Design of the Detector

The appearance of the SPM is shown in Figure 1.

The SPM of the alarm consists of a housing and a printed circuit board. On the front side of the printed circuit board (1) there are: Reset contacts (2), an opening sensor (3), a two-color LED indicator (4), a sound indicator (5), terminal blocks (6) for connecting a DC, a lithium battery (8) with an insulator (7), an antenna (10). The board is fixed in the base of the housing by a latch (9).

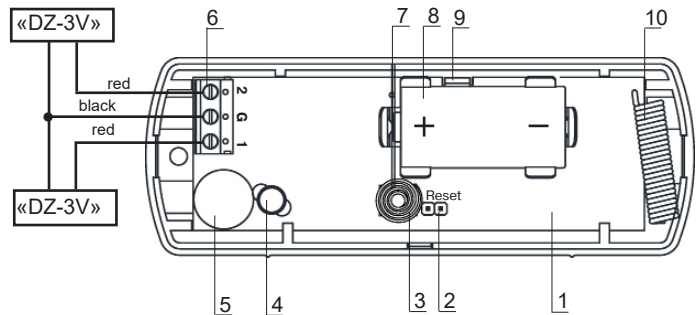

Figure 1 – The Base with the PCB

The «DZ-3V» layout is shown in Figure 2.

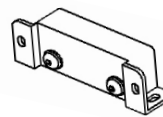

Figure 2 – Flood Sensor «DZ-3V»

The case of the FS is watertight, it is provided with sensing contacts and a 1.5 m cable for connecting to the SPM. The FS is designed to be fastened to both horizontal and vertical surfaces.

5 Sound and LED Indication

The Detector has the following indication modes:

- «Binding» procedure LED indication (procedure of logging in the CP);
- LED indication of the mode «Identification» – lights up by sending relevant command from CP and remains active during 15 min or until the case is opened;
- LED indication of the Detector state – lights up and remains unchanged for 15 min after the case is closed under conditions:
 - other LED indication types (except the sound alarm) absence;
 - alarm «Tamper» message is not generated during this time period;
 - the Detector state indication is ON upon the receipt of relevant command from the CP.

LED indicator modes are listed in the Table 3.

Table 3

The Detector Mode	Indication	Note
Binding procedure finished	LED lighting red for 2 – 3 sec	
«Binding» mode	LED blinking green with 0.25 sec period	The Detector logging in the CP in single-channel mode
	LED blinking green with 1 sec period	The Detector logging in the CP in double-channel mode
«Identification»	Alternate LED red and green alternate blinking	on command from the CP
«Alarm in Channel 1» «Alarm in Channel 2»	Single-shot LED lights up red for 4 sec *	State indication is on and «Identification» indication is off
Generation «Alarm in Channel 1» «Alarm in Channel 2»	Sound alarm dual switching **	State sound indication is on
Fallback recovery «Alarm in Channel 1» «Alarm in Channel 2»	Single-shot sound alarm switching **	

Table 3, continuation

The Detector Mode	Indication	Note
Radio communication quality appraisal	See sect. «Radio communication quality appraisal»	
«Failure in channel 1» «Failure in channel 2»	Orange LED indication dual blinking with 12 sec period *	State indication is on and «Identification» indication is off
«Normal»	Indication is off	
* LED indication of the Detector state ** Sound indication of the Detector state		

6 Binding with the CP

«Binding» mode is used for logging the Detector in the CP and service information exchange.

- 6.1 Prepare the CP in accordance with CP reference guide.
- 6.2 If it is necessary to log the Detector in double-channel mode, hook up TS to the Detector as shown in Figure or short-circuit the terminals of the Detector «-» and «G 2». For the single-channel mode neither hooking on, no short-circuit is required.
- 6.3 Observing the polarity, insert the battery (8) into the holder or remove the insulator (7).
- 6.4 Insert main battery to the holder plate (5) (if the battery is already set into the holder, than pull out the insulating foil).
- 6.5 Periodical LED indicator blinking green is evidence of binding process.
- 6.6 In case of mentioned above LED indication absence, short-circuit «Reset» terminals for 2 – 3 sec.
- 6.7 Successful binding procedure complying is indicated by LED indicator lighting red for 2 – 3 sec.
- 6.8 The time limit for the binding process of the Detector is 100 sec. To restart the binding procedure, short-circuit «Reset» terminals for 2 – 3 sec.

7 «Stand Alone» mode

- 7.1 The Detector changes to stand alone mode upon the expiry of 100 sec binding procedure.
- 7.2 During operation in the stand alone mode LED and sound indication is always ON under condition of «Tamper» message absence.
- 7.3 The Detector has no communication with CP and its state is displayed only by means of LED and sound indication (see Table 4).

Table 4

The Detector Mode	Indication	Period
«Failure in Loop 1» «Failure in Loop 2»	Double-shot LED lighting orange for 2 sec Sound indicator single-shot actuation	12 s
«Low Battery»	LED lighting orange for 2 sec	12 s
«Alarm in Loop 1» «Alarm in Loop 2»	LED lighting red for 2 sec Sound indicator single-shot actuation	4 s
«Norm»	Green LED single-shot blinking	12 s

8 Communication Quality Appraisal

- 8.1 For radio communication quality appraisal it is necessary to:
 - set the Detector on the assumed place of installation;
 - push and then release case tamper.
- 8.2 After case tamper releasing the Detector generates case tamper alarm message, transmits it via radio communication channel and represents communication quality with CP by LED indication in accordance with the Table 5.

Table 5

LED Indication		Radio communication quality appraisal	Recommendations
Color	Mode		
Green	Three blinks	Excellent	Install the Detector on this place
Green	Two blinks	Good	
Green	One blink	Communication established	Choose another place for installation or use a repeater*)
Red	Four blinks	No communication	
* «Ladoga-RK» system repeater			

9 Installation

- 9.1 Drill holes for fastening the Detector elements. You may use the FD and the SPM base without the PCB for marking out the holes.
- The FS should be located in the place, where the water spilled in the detection zone close the sensor contacts. The FS installation with the terminals downwards ensures generation of alarm signal over appearance the liquid sheet with a thickness exceeding 1 mm. The FS installation with the terminals sidewise provides easy access to the sensor terminals for removal of a liquid from the FS surface between the terminals after the leakage elimination.
- 9.2 Fasten the FS on the mounting surface with screws or a water-resistant glue. Fasten the SPM base on the mounting surface with screws. For the wall-tamper monitoring, the second screw must be screwed in a hole under the wall tamper. Install the PCB, connect the FSs to the loop terminals (the red wire to the «+» terminal). Install the cover.

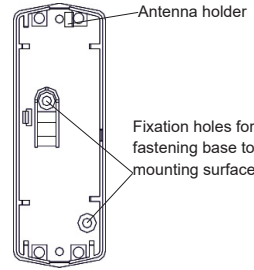

Figure 3 - SPM base

9.3 Fix the DZ to the mounting surface with screws or waterproof glue. Secure the base of the BOS housing with screws.
Install the printed circuit board and connect the DC to the terminal blocks (6) according to Figure 1. Close the cover of the SPM.
ATTENTION! Antenna should be installed into the holder (see Figure 3). Antenna installation outside of the holder essentially reduces communication range.

10 Troubleshooting

Table 6

CP Message	Elimination Procedure
«Tamper»	Close the lid
«Alarm in Loop 1» «Alarm in Loop 2»	In case there is no liquid (moisture) between the FS contacts, check the absence of a short circuit between the wires
«Failure in Loop 1» «Failure in Loop 2»	Check the integrity of the wires connecting the FS and the SPM and their fastening to the SPM terminals
«Low Battery»	Replace the battery

11 Manufacturer's Guarantees

- 11.1 The manufacturer guarantees conformity of the Detector to the requirements of technical conditions provided the transportation, storage, installation and operation conditions are observed.
- 11.2 The guaranteed shelf life of the Detector is 63 months since the date of manufacture. The guaranteed useful life is 60 months since the day of putting into operation within the limits of the guaranteed shelf life.
- 11.3 The detectors that are found non-conforming to the requirements of the specifications will be repaired by the manufacturer, provided the installation and operation rules have been observed.

Note – Warranty obligations do not apply to batteries.

12 Storage and Transportation

- 12.1 The Detectors are transported without power supply battery. The Detector in their original packaging are resistant to:
 - transport jolting with the acceleration up to 30 m/sec² at impact frequency range from 10 to 120 per minute or 15 000 strikes;
 - ambient temperature range minus 50 ... +50 °C;
 - relative air humidity (95 ± 3) % at a temperature +35 °C.
- 12.2 The Detector in original package may be transported by any means of transportation in closed vehicles over any distances in compliance with the existing shipping rules concerning the respective means of transportation.
- 12.3 After transportation under the conditions different to exploitation conditions the Detector shall be ready to operate after a maximum of six hours.
- 12.4 The storage room shall be free from current-conducting dust, acid vapors, alkali and gases that cause corrosion and destroy insulation.

13 Packing Certificate

Wireless flood sensor «STZ-RK» manufactured in accordance with current technical documentation is classified as fit for operation and is packed by «Development and Production Enterprise RIELTA» LLC.

Packing date _____ month, year

Made in Russia

Rev. 6 of 21.05.2024
v.13.1

«Development and Production Enterprise RIELTA» LLC
Petrogradskaya nab., 34, letter B, Saint Petersburg, Russia, 197046
www.rielta.com, rielta@rielta.com
Tel./fax: +7 (812) 233-0302, 703-1360, support@rielta.com
Technical support, tel.: +7 (812) 233-29-53, 703-13-57, support@rielta.com