



# PASSIVE INFRARED WIDE ANGLE DETECTOR

## «FOTON-15»

### Installation Guide

#### 1 General Information

Passive infrared wide angle detector «Foton-15» (hereinafter, the Detector) is designed for detecting intrusion into a protected space and generating an alarm message by consumption current value changing.

The Detector can be installed in heated or unheated spaces having different application: in museums, offices, cottages, flats, shops, as well as in warehouses, garages, hangars.

The Detector generates three types of messages:

- «Norm»;
- «Alarm»;
- «Tamper».

The Detector provides digital temperature compensation of it's detectability.

#### 2 Features

- Dual-element pyrodetector;
- Power supply by the alarm loop (AL);
- Immunity to insect's intrusion to the pyrodetector;
- Swivel bracket (supplied) providing ease of Detector installation and detection zone repositioning;
- LED indicator for the Detector operation visual control. LED indication is switched ON or disabled by applying a jumper to one of the «IND» wafer position («ON» or «OFF»);
- Two modes of alarm messages generation: «Short-circuit» (SC) (by increasing current consumption value) and «Open-circuit» (OC) (by decreasing current consumption value). Required operation mode is assigned either by removal SC jumper, or by applying OC jumper to the «OC» wafer position.

#### 3 Principal Technical Characteristics

Table 1

Parameter	Value
Detection zone types	wide angle
Maximum detection range, not less than	12 m
Detection angle in horizontal plane	90°
Mounting height	2.3 m
Detected speed range	0.3 – 3 m/sec
Alarm message duration, not less than	2 sec
Warm-up time, not more than	60 sec
Power supply	8 – 72 V DC
Current consumption in «NORM» mode: SC mode, not more than OS mode, adjustable	0.1 mA 2 ... 15 mA
Operation temperature	minus 30 ... +50 °C
Relative humidity under 25 °C without moisture condensation	95 %
IP rating	IP41
Dimensions, maximum	126 x 70 x 55 mm
Mass, not more	0.15 kg

#### 4 Detection Zone Pattern

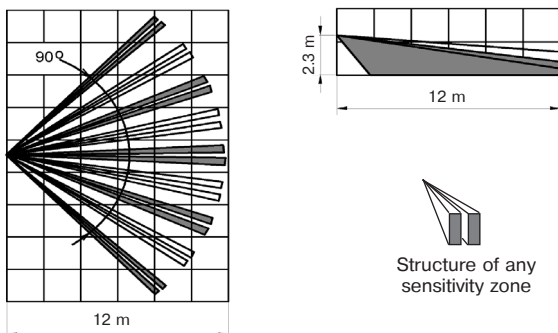

Figure 1 – Detection Zone Pattern

#### 5 Scope of delivery

Each Detector unit package contains the items listed in Table 2.

Table 2

Name	QNT.
Passive infrared wide angle detector «Foton-15»	1 pc.
Swivel bracket	1 pc.
Screw 3-3x30.016	2 pcs.
Passive infrared wide angle detector «Foton-15». Installation Guide	1 copy

#### 6 The Detector Design

The Detector comprises base, printed circuit board (PCB) and a cover. Swivel bracket is included in scope of delivery.

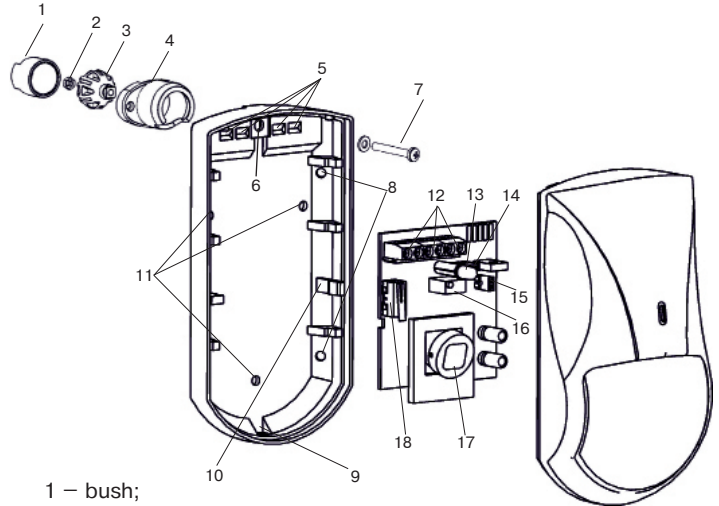

- 1 – bush;
- 2 – nut;
- 3 – sphere;
- 4 – swivel bracket case;
- 5 – openable holes for wiring;
- 6 – openable hole for fastening to swivel bracket;
- 7 – screw;
- 8 – openable holes for corner mounting;
- 9 – opening for cover holder;
- 10 – PCB fixing arm;
- 11 – openable holes for wall mounting;
- 12 – leading-in sockets for AL plugging;
- 13 – LED indicator;
- 14 – LED indication ON/OFF jumper;
- 15 – Operating modes changeover SC/OP jumper;
- 16 – potentiometer for current consumption adjustment;
- 17 – pyrodetector;
- 18 – case ramper.

Figure 2 – Design of the Detector

#### 7 Choosing Place of Installation

When choosing the Detector installation place, take note of the fact that the detection zone may be limited by non-transparent objects (curtains, houseplants, cabinets, bookcases, etc.), as well as glass and mesh partitions. There must be no windows, air conditioners, space heaters or heating radiators in the Detector visibility range.

When mounting choose the Detector orientation in such a position, that any potential directions of intrusion should cross sensitive zones of the Detector.

Power supply and alarm loops should be wired far enough from load cables. There must be no animals or birds in the protected space.

#### 8 The Detector Installation

Choose the place of installation (Cl. 7):

- unfasten the latch through the opening, which is situated downside the detector case by means of screwdriver and put off the detector cover (Figure 2);
- when installing the detector without swivel bracket it is necessary to put off the PCB by means of pushing up it's fixing arm;
- drill the holes in the base of the detector for wiring and fastening the detector;
- choose the place of installation, mark the places for mounting holes with the regard to detector base (or swivel bracket) openings;
- drill the holes in the wall with regard to market places;
- pass the wire through the mounting holes in the base, leaving several centimeters of installation wire for it's fastening inside the case;
- fix the base of the detector case on the wall (swivel bracket) at the chosen place. In case of swivel bracket using, unscrew the cap screw from the swivel bracket sphere. Fit the square bulge of the swivel

bracket external sphere with the corresponded opening on the detector base. Plug in the screw to the opening in the top of the detector base and fix connection by the screw;

- put PCB on it's place, plug loop wirings in accordance with Cl. 9;
- close the cover.

### 9 Variants of the Detector Connection

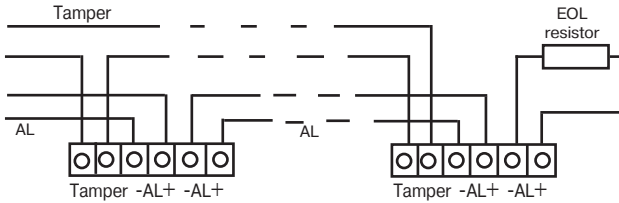

a) In parallel to terminal EOL element - SC mode

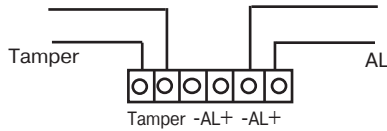

b) Instead of EOL resistor - OC mode

Figure 3 – Connection Pattern

If connection of the Detector to the loop is fulfilled in parallel to terminal element (Figure 3a), you should preliminarily set the alarm current value with allowance for the real load-carrying capacity of the loop. For this purpose act as follows:

- apply an OS jumper on the wafer located on the Detector PCB;
- fulfill connection of the Detector to the loop and energize it;
- make sure, that control panel (hereinafter, CP) got an alarm signal, and input voltage value on AL contacts remains not less than 8 V;
- if value of input voltage on AL contacts is less than 8 V, then using the potentiometer slider set value of consumption current, at which input voltage value on AL contacts remains not less than 8 V, and CP registers an alarm message;
- remove OS jumper on the PCB and check the Detector operability according to the method described in the following chapter.

Take a note that the loop resistance with allowance for summary current consumption of the Detector in standby mode and current let-through the EOL resistor should be in the limits, which the CP identifies as «Norm». Adjustment of alarm value OS fulfilled by means of potentiometer consequently in turn for each Detector while OS jumpers at other Detectors are removed.

When the Detector is hooked up to the loop instead of a terminal (EOL) element (Figure 3b), Adjust by «current» potentiometer such a value of useful current in standby mode, that provides the same voltage on AL contacts as on EOL element loop.

**ATTENTION!** If the Detector is planned to be in use with disabled indication, then adjustment should be fulfilled with the indication disabled.

### 10 Functional Testing

- Energize the Detector and wait for 60 – 70 sec before functional testing performance.

- Start walking through the detection zone. After movement detection, «Alarm» message is displayed by LED indication of the Detector. The Detector must reveal a human, moving at a speed 0.3 ... 3 m/sec after 3 – 4 steps within the detection zone limits. Upon the movement absence in the protected space, «Alarm» message should not been generated.

**ATTENTION!** The Detector must be checked at least annually in order to test it's performance.

### 11 Transportation and Storage

11.1 The Detectors in their original packing may be shipped by any transport means in covered vehicles (in railway, cars, trucks, sealed heated compartments of aircraft, ship cargo holds, etc). The storage room should be free from current-conducting dust, acid vapors, alkali and gases that cause corrosion and destroy insulation

11.2 The Detectors in their original packing may be stored not more than 3 months. During this period the Detector package should not have bloodshot spots and impurities.

11.3 Upon the expiry of 3 months, the Detector should be released from the package.

### 12 Manufacturer's Guarantees

The Manufacturer guarantees conformity of the Detector to it's Technical Specifications if conditions of transportation, storage, assembling and operation are observed. The guaranteed storage period is 63 months since the date of manufacturing the Detector.

The guaranteed period of operation is 60 months since the date of commissioning within the storage period guaranteed.

The Detectors that are found to non-conforming to it's Technical Requirements shall be repaired by the Manufacturer, provided the installation and operation rules have been complied with.

### 13 Acceptance and Packing Certificate

Passive infrared wide angle detector «Foton-15»,

serial number \_\_\_\_\_,

has been manufactured in compliance with the active technical documentation and classified as fit for operation and packed by «Development and Production Enterprise RIELTA » LLC.

Person in charge of acceptance and packing

QC representative \_\_\_\_\_ day, year, month