

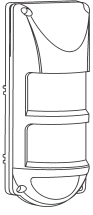

# PASSIVE INFRARED DETECTOR

## «FOTON-22B»



### Installation Guide

#### 1 General Information

1.1 Passive infrared security vertical curtain detector «Foton-22B» (hereinafter, the Detector) is intended to detect intrusion into the controlled indoor space and to generate the «Alarm» message.

The Detector ensures protection against attempts of case tampering or case tilt changing.

1.2 The Detector is designed to operate continuously around the clock.

1.3 The Detector provides high resistance level to false alarms and small animals movement.

1.4 Industrial radio interference generated by detectors during operation does not exceed the rates established for residential spaces.

1.5 The Detector can be installed on the wall or corner of the room. Wall or corner mounting by means of swivel bracket is also possible.

#### 2 Features

- Sensing elements – three dual-element pyrodetectors, three detection channels.
- Protection against intrusion of insects to a pyrodetector.
- Microprocessor-based signal processing.
- Choosing of the following modes: testing, detection range, alarm memory, and LED indication.
- Ensurance of self-test mode with operability testing of sensing elements in each detection channel.
- Digital temperature compensation.
- The Detector is supplied from DC current supply unit with output voltage (8 ... 28) V.
- The Detector comprises tilt sensor for detection of the Detector case position changing.
- Swivel bracket for detection zone position changing is supplied.

#### 3 Specifications

Table 1

Parameter	Value
Maximum detection range with DIP-switch 1 set in position: - ON - OFF	20 m 12 m
Mounting height	2 ... 3 m
Detected speed range	0.3 ... 3 m/sec
Detection angle in horizontal plane	8°
Alarm message duration, not less than	2 sec
Power supply range, DC	8 ... 28 V
Consumption current, not more	30 mA
Operating temperature	minus 50 ... +50 °C
Maximum voltage and current, commutated at relay contacts, not more	72 V 30 mA
Permissible relative humidity at a temperature +35 °C without moisture condensation	98 %
Ambient class	Boreal Climate*
IP rating	IP54
Dimensions, maximum	180 x 70 x 60 mm
Weight, maximum	0.2 kg
Average service life, not less than	8 years

\* background temperature 15 – 35 °C, relative humidity 25 – 75 %, air-pressure 86 – 106 kPa.

Detection zone pattern is shown in Figure 1.

#### 4 Field of Application

The Detector is designed for operation in non-heated areas with excessive interference level.

#### 5 Scope of Delivery

Each Detector unit package contains the items listed in Table 2.

Table 2

Name	QNT
Passive infrared detector «Foton-22B»	1 pc.
Screw 3-3x30.016	2 pcs.
Rubber bushing for wiring	2 pcs.
Plastic potting compound	1.0 ± 0.5 g
Wall Plug NAT SORMAT	2 pcs.
Swivel bracket	1 pc.
Passive infrared detector «Foton-22B». Installation Guide	1 copy

#### 6 Choosing the Place of Installation

The Detector is intended for application in heated or non-heated objects. When choosing the Detector installation place, it is advisable to take note of the fact that the detection zone may be limited by non-transparent objects (curtains, houseplants, cabinets, bookcases, etc.), as well as by glass and mesh partitions. There must be no windows, air conditioners, space heaters or heating radiators in the PIR-detection zone. When installing at a height of 2.3 to 3 m, the use of a bracket is required. (for range and tilt angle see table 3)

The Detector wires should be laid far enough from power supply cables at a distance not less than 0.5 m.

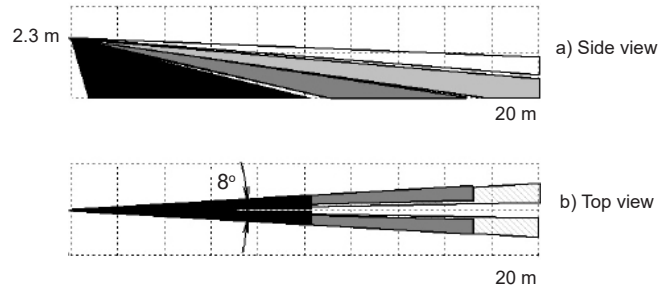

Figure 1 – Detection Zone Pattern

#### 7 Design

7.1 The Detector (Figure 1) consists of base (1) with PCB (3) and cover (5). Swivel bracket (see Figure 3) is included in scope of delivery. The cover is fixed to the base by four screws (6) with a sealing gasket along the base perimeter. The PCB is fixed on the base by means of latch (10), spring latch (11) and screw (9).

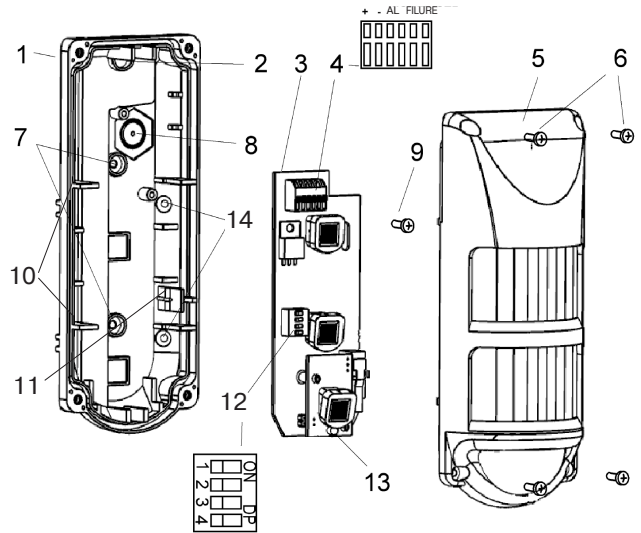

Figure 2 – The Detector Design

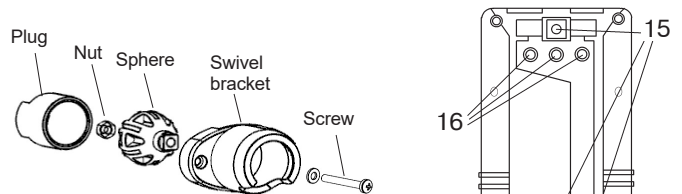

Figure 3 – Swivel Bracket Components

For the Detector fixing to the swivel bracket, square shape recesses (15) for the Detector fastening to swivel bracket and openable holes for wiring (16) are located on the reverse side of the base.

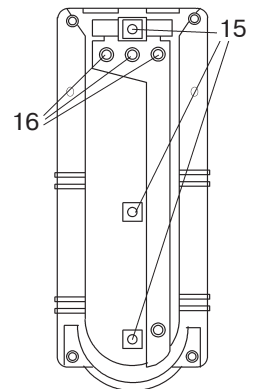

Figure 4 – Reverse side of the Base

#### 8 Assembling and Mounting

8.1 Turn out four screws (6) and open the cover.

8.2 Reverse screw (9), press the latch (11) and remove the PCB from the base.

8.3 Open necessary number of holes (16) for wiring in the base (Figure 4).

8.4 For the Detector installation without swivel bracket open fixation holes (7) for wall mounting or holes (14) for corner mounting.

8.5 In case of the Detector installation on the swivel bracket:

- assemble the swivel bracket in accordance with Figure 3;
- fasten assembled swivel bracket to the wall (Ceiling) by screws;
- open one of 3 holes (15) for the Detector fastening to swivel bracket.

**Note** – Use the base with removed PCB as a pattern for marking of fixation holes on the mounting surface.

8.6 Insert the power and AL wires inside the case through the rubber bushings and fix the base either to the fastened swivel bracket or to the mounting surface by screw nails.

8.7 All opened holes in the Detector base should be hermetically sealed by supplied plastic potting compound.

8.8 Install PCB to the Detector base, hook up power and AL wires in accordance with designation on the PCB and control panel Installation Guide and fix them on the connecting block (4).

Alignment of the detection zone position is fulfilled by means of the Detector rotation on the swivel bracket. Recommended values of tilt forward (see Figure 5) are listed in Table 3.

Table 3

Mounting Height	PCB Position, $\alpha$	Detection Range
2 ... 2.3 m	0°	up to 20 m
2.5 ... 3.5 m	8°	up to 12 m
3.5 ... 4.5 m	19°	up to 8 m
4.5 ... 5 m	30°	up to 6 m

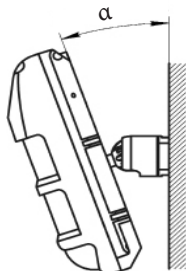

Figure 5

After thy Detector position changing check the detection zone position.

## 9 Information Capacity

Table 4

Messages	LED Indication State	Relay Status	
		AL	FAILURE
«Warm-up Time»	Blinking at 1 Hz frequency during 60 sec after energizing	Opened	Opened
«Norm»	OFF	Closed	Closed
«Alarm»	Lighting for not less than 2 sec	Opened	Closed
«Failure»: - power supply lower 8 V	Single-shot periodical blinking	Opened	Opened
- maximum permissible temperature exceeding	Double-shot periodical blinking	Opened	Opened
- negative result of detection channel testing	Triple-shot periodical blinking	Opened	Opened
- case tilt or tampering	OFF	Closed	Opened
Detection zone alignment	Lighting during 0.25 sec at each detection zone beam crossing	Closed	Closed

## 10 Switching ON and Testing

To ensure detection range 20 m, set DIP-switch «1» to ON position. If detection zone length should be less than 12 m (small room), it is recommended to set DIP-switch «2» to OFF position. Along with that higher sensitivity level is provided. It is advisable to use this mode of the Detector operation in small rooms with severe interference conditions.

After Detector energizing, self-testing of the detector is going on during 1 minute. During this procedure voltage supply, environment temperature and amplification path tests are conducted, LED blinks red (DIP-switch «3» in ON position), AL contacts are opened.

During self-testing procedure fulfilment, no movements inside the detection zone should not take place, since the Detector is in process of adaptation to the surroundings, and any movement can prolong «Warm-up time» mode.

## 11 Functional Testing

Upon the «Warm-up time» mode expiry, the detector turns to standby mode, and is ready for alarm message generation.

### Testing Mode

DIP-switches position: «3» – ON, «2» – ON.

This mode is intended for the each beam of the detecting zone positioning. In case of each beam crossing, the LED indicator switches for 0.25 sec. Optimal travel speed at maximal detection range – 0.5 m/sec.

**Note** – In this mode there is no LED indication of alarm message generated by relay contacts opening.

Under the movement absence in the secured zone, the LED indicator should not light. After 5 min testing the detector changes to normal operation mode (in case of DIP-switch «3» position is ON, alarm message generation is indicated by LED indicator lighting during not less than 2 sec).

### Sensitivity Testing

DIP-switches position: «3» – ON, «2» – OFF.

This mode is intended for the Detector sensitivity appraisal (the travel length measured from the moment of detection till alarm message generation). The alarm message should be generated after 2 – 4 steps within the detection zone during 3 sec.

Wait for 8 – 10 sec after each alarm until the LED is off and continue walking across the detection zone.

**Note** – If detection of moving objects in the detection zone is failed, Detector position on the swivel bracket should be changed (In case of wall mounting the rotation angle in horizontal plane  $\pm 45^\circ$ ).

## 12 Alarm Memory

DIP-switches position: «3» – ON, «4» – ON.

LED indicator switches red in 5 min after alarm message generation. Indication period is 15 min.

## 13 LED Indicator Disabling

For the Detector operation masking, indication disabling mode is provided. Set DIP-switch «3» in OFF position.

## 14 Self-testing and Failure Indication

The Detector carries out self-testing automatically, processing:

- availability of the receiver with amplifier;
- power supply;
- ambient temperature.

In temperature range near to 36 °C, the sensitivity threshold shift takes place with the detectability level increase.

The detector is generating «Failure» message during period not less than 15 min (list of failures see in Table 4).

In 15 min after elimination of failure reasons, the Detector returns to switching on to standby mode or to switching on and testing mode.

**ATTENTION!** The Detector must be checked at least annually in order to test their performance.

## 15 Manufacturer's Guarantees

15.1 The Manufacturer guarantees conformity of the detector to the requirements of specification provided that conditions of transportation, storage, assembling and operation are observed.

The guaranteed storage period is 63 months since the date of manufacturing the detector.

15.2 The guaranteed period of operation is 60 months since the date of commissioning within the storage period guaranteed.

15.3 If non-conformity of the detector to technical requirements is detected during the guaranteed period provided that rules of operation are observed it shall be repaired by the Manufacturer.

## 16 Storage and Transportation

16.1 The storage room should be free from current-conducting dust, acid vapors, alkali and gases that cause corrosion and destroy insulation.

16.2 Detectors packed for shipping should be stored no more than 3 months. The shipping package shall be free from leaks and dirt.

16.3 In case of storage over 3 months detectors should be unpacked.

16.4 Factory-packed detectors can be shipped by any transport means in covered vehicles (in railway cars, trucks, sealed heated compartments of aircraft, holds etc).

## 17 Packing Certificate

Passive infrared detector «Foton-22B» has been manufactured in compliance with the active technical documentation and classified as fit for operation and packed by «Development and Production Enterprise RIELTA» LLC.

Packing date \_\_\_\_\_ month, year